

Single leg brush holders for sliprings

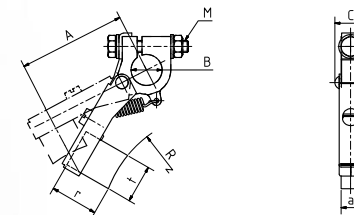

Type number	Brush dimensions			Radius R	Length* A	Bore diameter B		Width C	Connection screw M
	t	a	r			standard	max		
DE43.21.(B...)	4	3	10	At customer's option	21	7	8	7	M3
DE63.23.(B...)	6	3	15		23	7	8	7	M3
DE84.32.(B...)	8	4	15		32	8	10	8	M4
DE84.43.(B...)	8	4	15		43	8	10	8	M4
DE85.27.(B...)	8	5	15		27	8	10	9	M3
DE85.32.(B...)	8	5	15		32	8	10	9	M4
DE85.43.(B...)	8	5	15		43	8	10	9	M4
DE105.30.(B...)	10	5	16		30	8	10	9	M4
DE105.37.(B...)	10	5	16		37	8	10	9	M4
DE1064.37.(B...)	10	6.4	16		37	8	10	11	M4
DE1064.47.(B...)	10	6.4	16		47	8	10	11	M4
DE12564.40.(B...)	12.5	6.4	20		40	8	10	11	M4
DE12564.45.(B...)	12.5	6.4	20		45	8	10	11	M4
DE1258.47.(B...)	12.5	8	20		47	10	13	12	M5
DE168.40.(B...)	16	8	20		40	10	13	12	M5
DE168.46.(B...)	16	8	20		46	10	13	12	M5
DE168.50.(B...)	16	8	20		50	10	13	12	M5
DE168.62.(B...)	16	8	25		62	13	16	12	M5
DE1610.50.(B...)	16	10	25		50	10	16	14	M5
DE1610.62.(B...)	16	10	25		62	13	16	14	M5
DE208.50.(B...)	20	8	25		50	13	16	12	M5
DE208.60.(B...)	20	8	25		60	13	16	12	M5
DE2010.50.(B...)	20	10	25		50	10	13	14	M5
DE2010.56.(B...)	20	10	25		56	13	16	14	M5
DE2010.60.(B...)	20	10	25		60	13	16	14	M5
DE2010.70.(B...)	20	10	30		70	16	20	14	M5
DE258.60.(B...)	25	8	25		60	13	16	12	M5
DE258.70.(B...)	25	8	25		70	13	16	12	M5
DE2510.60.(B...)	25	10	25		60	13	16	14	M6
DE2510.70.(B...)	25	10	30		70	16	20	14	M6
DE25125.70.(B...)	25	12.5	30		70	16	20	17	M6
DE25125.80.(B...)	25	12.5	30		80	16	20	17	M6
DE25125.90.(B...)	25	12.5	30		90	16	20	17	M6
DE2516.85.(B...)	25	16	30		85	16	20	22	M8
DE3210.67.(B...)	32	10	32		67	13	16	15	M6
DE3210.80.(B...)	32	10	32		80	13	20	15	M6
DE32125.70.(B...)	32	12.5	32		70	16	20	17	M6
DE32125.80.(B...)	32	12.5	32		80	16	20	17	M6
DE32125.90.(B...)	32	12.5	32		90	16	20	17	M6
DE3216.85.(B...)	32	16	32		85	16	20	22	M8
DE3216.100.(B...)	32	16	32	100	16	20	22	M8	
DE4020.100.(B...)	40	20	40	100	16	20	26	M10	
DE4020.125.(B...)	40	20	40	125	25	-	26	M10	
DE4020.140.(B...)	40	20	40	140	25	-	26	M10	

Above dimensions are standard. Special dimensions available on request.
* Length of holder arm when fitted

More Leg brush holders (1 of 6)



- Overview
- Leg brush holders
- Brush holders with clamps
- Brush holder bolts
- Self-recoiling springs
- Tubular brush holders
- Small slipring systems
- Flange brush holders /Brush rockers

Double leg brush holders for sliprings

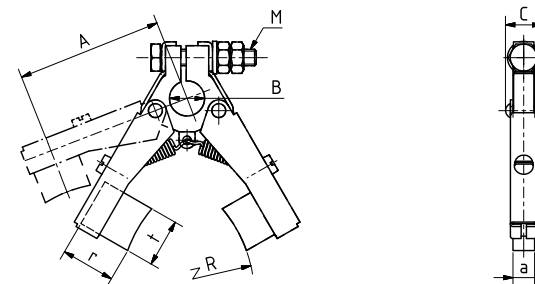

Designs

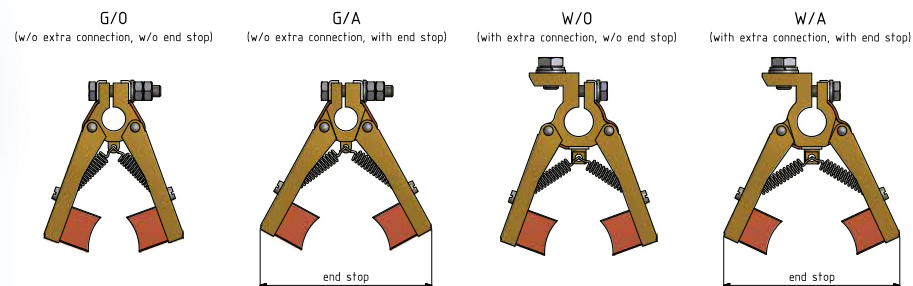

Type number	Brush dimensions			Radius R	Length* A	Bore diameter B		Width C	Connection screw M
	t	a	r			standard	max		
DD43.21.(B...)	4	3	10	At customer's option	21	7	8	7	M3
DD63.23.(B...)	6	3	15		23	7	8	7	M3
DD84.32.(B...)	8	4	15		32	8	10	8	M4
DD84.43.(B...)	8	4	15		43	8	10	8	M4
DD85.32.(B...)	8	5	15		32	8	10	9	M4
DD85.43.(B...)	8	5	15		43	8	10	9	M4
DD105.29.(B...)	10	5	16		29	8	10	9	M4
DD105.37.(B...)	10	5	16		37	8	10	9	M4
DD1064.35.(B...)	10	6.4	16		35	8	10	11	M4
DD1064.45.(B...)	10	6.4	16		45	8	10	11	M4
DD12564.40.(B...)	12.5	6.4	20		40	8	10	11	M4
DD12564.45.(B...)	12.5	6.4	20		45	8	10	11	M4
DD1258.40.(B...)	12.5	8	20		40	10	13	12	M5
DD1258.50.(B...)	12.5	8	20		50	10	13	12	M5
DD168.42.(B...)	16	8	20		42	10	13	12	M5
DD168.52.(B...)	16	8	20		52	10	13	12	M5
DD168.50.(B...)	16	8	20		50	10	13	12	M5
DD168.62.(B...)	16	8	25		62	13	16	12	M5
DD1610.50.(B...)	16	10	25		50	10	16	14	M5
DD1610.62.(B...)	16	10	25		62	13	16	14	M5

Above dimensions are standard. Special dimensions available on request.
Please specify design and optional end stop when ordering.
* Length of holder arm when fitted

More Leg brush holders (2 of 6)



- Overview
- Leg brush holders
- Brush holders with clamps
- Brush holder bolts
- Self-recoiling springs
- Tubular brush holders
- Small slipring systems
- Flange brush holders / Brush rockers

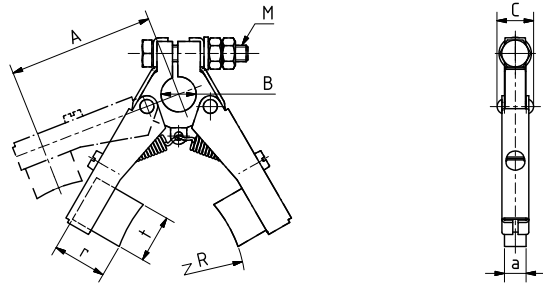

Type number	Brush dimensions			Radius R	Length* A	Bore diameter B		Width C	Connection screw M
	t	a	r			standard	max		
DD208.50.(B...)	20	8	25	At customer's option	50	13	16	12	M5
DD208.60.(B...)	20	8	25		60	13	16	12	M5
DD2010.50.(B...)	20	10	25		50	10	13	14	M5
DD2010.60.(B...)	20	10	25		60	13	16	14	M5
DD2010.70.(B...)	20	10	30		70	16	20	14	M5
DD258.52.(B...)	25	8	25		52	13	16	12	M5
DD258.60.(B...)	25	8	25		60	13	16	12	M5
DD2510.60.(B...)	25	10	25		60	13	16	14	M6
DD2510.70.(B...)	25	10	30		70	16	20	14	M6
DD25125.60.(B...)	25	12.5	25		60	13	16	17	M6
DD25125.70.(B...)	25	12.5	30		70	16	20	17	M6
DD25125.80.(B...)	25	12.5	30		80	16	20	17	M6
DD25125.90.(B...)	25	12.5	30		90	16	20	17	M6
DD2516.85.(B...)	25	16	30		85	16	20	22	M8
DD3210.70.(B...)	32	10	32		70	13	16	15	M6
DD3210.80.(B...)	32	10	32		80	13	20	15	M6
DD32125.80.(B...)	32	12.5	32		80	16	20	17	M6
DD32125.90.(B...)	32	12.5	32		90	16	20	17	M6
DD32125.100.(B...)	32	12.5	32		100	16	20	17	M6
DD3216.90.(B...)	32	16	32		90	16	20	22	M8
DD3216.100.(B...)	32	16	32	100	16	20	22	M8	
DD4020.100.(B...)	40	20	40	100	16	20	26	M10	
DD4020.125.(B...)	40	20	40	125	25	-	26	M10	
DD4020.140.(B...)	40	20	40	140	25	-	26	M10	

Above dimensions are standard. Special dimensions available on request.
Please specify design and optional end stop when ordering.
* Length of holder arm when fitted

Single leg brush holders made of plastic

Type number	Brush dimensions			Radius R	Length* A	Bore diameter B		Width C	Connection screw M
	t	a	r			standard	max		
KDE84.33.08.99.00	8	4	15	At customer's option	33	8	10	9	M3
KDE84.43.08.99.00	8	4	15		43	8	10	9	M3
KDE84.35.10.99.00	8	4	15		35	10	13	9	M4
KDE84.45.10.99.00	8	4	15		45	10	13	9	M4
KDE85.33.08.99.00	8	5	15		33	8	10	9	M3
KDE85.43.08.99.00	8	5	15		43	8	10	9	M3
KDE85.35.10.99.00	8	5	15		35	10	13	9	M4
KDE85.45.10.99.00	8	5	15		45	10	13	9	M4

Double leg brush holders made of plastic

Type number	Brush dimensions			Radius R	Length* A	Bore diameter B		Width C	Connection screw M
	t	a	r			standard	max		
KDD84.33.08.99.00	8	4	15	At customer's option	33	8	10	9	M3
KDD84.43.08.99.00	8	4	15		43	8	10	9	M3
KDD84.35.10.99.00	8	4	15		35	10	13	9	M4
KDD84.45.10.99.00	8	4	15		45	10	13	9	M4
KDD85.33.08.99.00	8	5	15		33	8	10	9	M3
KDD85.43.08.99.00	8	5	15		43	8	10	9	M3
KDD85.35.10.99.00	8	5	15		35	10	13	9	M4
KDD85.45.10.99.00	8	5	15		45	10	13	9	M4

* Length of holder arm when fitted

More Leg brush holders (3 of 6)



- Overview
- Leg brush holders
- Brush holders with clamps
- Brush holder bolts
- Self-recoiling springs
- Tubular brush holders
- Small slipping systems
- Flange brush holders /Brush rockers

Double leg brush holders for sliprings with self-aligning brushes

TYPE DDG



Design 1

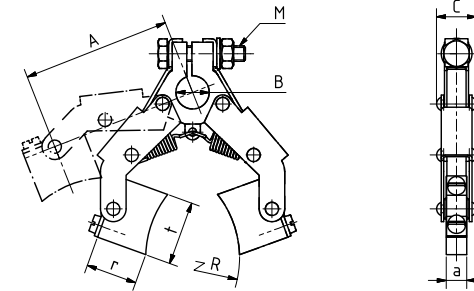

Design 2

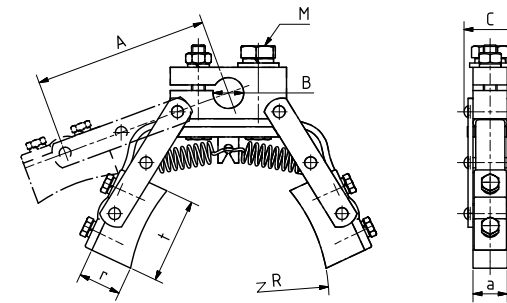

Type number	Brush dimensions			Radius R	Length* A	Bore diameter B		Width C	Conection screw M	max. current	Design
	t	a	r			standard	max				
DDG224.40,(B...)	22	4	18	At customer's option	40	8	10	7.5	M 4	25 A	1
DDG1664.40,(B...)	16	6.4	13		40	8	10	11.5	M 4	25 A	1
DDG2264.40,(B...)	22	6.4	13		40	8	10	11.5	M 4	30 A	1
DDG258.60,(B...)	25	8	20		60	12	16	13.5	M 5	60 A	1
DDG3210.60,(B...)	32	10	20		60	12	20	15.5	M 8	150 A	1
DDG3216.65,(B...)	32	16	20		65	12	20	22	M 8	180 A	1
DDG4514.80,(B...)	45	14	25		80	16	20	23	M 10	220 A	2
DDG4516.80,(B...)	45	16	25		80	16	20	27	M 12	265 A	2
DDG4516.95,(B...)	45	16	25		95	16	20	27	M 12	265 A	2
DDG5020.95,(B...)	50	20	25		95	16	20	30	M 12	350 A	2
DDG6025.105,(B...)	60	25	25		105	17	20	36	M 12	500 A	2

Above dimensions are standard. Special dimensions available on request.
* Length of holder arm when fitted

More
Leg brush holders
(4 of 6)



- Overview
- Leg brush holders
- Brush holders with clamps
- Brush holder bolts
- Self-recoiling springs
- Tubular brush holders
- Small slipring systems
- Flange brush holders /Brush rockers

Bolt distance

Table to determine bolt distance (Ab)

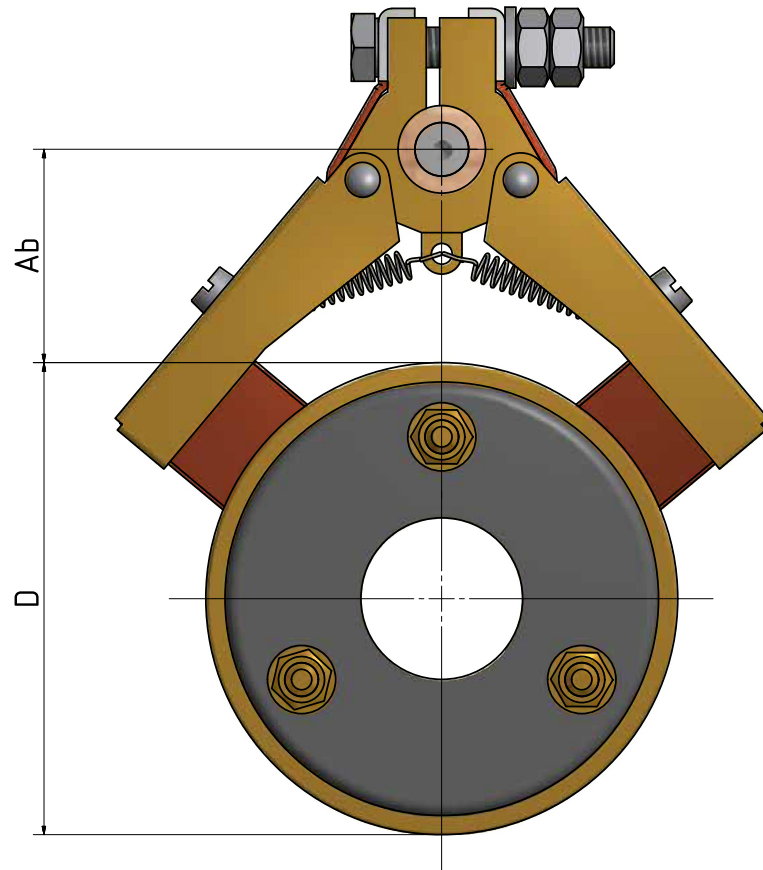

Type number	Bore diameter	Slipping diameter (D)								
		50	75	100	150	200	250	300	350	400
DD43.21.07	7	15	14	14						
DD63.23.07	7	15	14	14						
DD84.32.08	8	20	19	18	17	17	17			
DD84.43.08	8	24	21	20	19	18	17			
DD85.32.08	8	20	19	18	17	17	16			
DD85.43.08	8	24	21	20	19	18	17			
DD105.29.08	8	23	21	20	19	18	17			
DD105.37.08	8	23	21	20	19	18	17			
DD1064.35.08	8	24	21	20	19	18	17			
DD1064.45.08	8	24	21	20	19	18	17			
DD12564.40.08	8	25	22	21	20	20	20	20	20	20
DD12564.45.08	8	25	22	21	20	20	20	20	20	20
DD1258.40.10	10	25	25	22	22	20	20	20	20	20
DD1258.50.10	10	30	28	28	25	25	24	24	22	22
DD168.42.10	10	30	28	28	25	25	24	24	22	22
DD168.52.10	10	30	30	30	28	28	25	25	24	24
DD168.50.10	10	28	28	28	25	25	25	22	22	22
DD168.62.13	13			28	28	25	25	22	22	22
DD1610.50.10	10		32	30	30	25	25	22	22	22
DD1610.62.13	13		32	30	30	25	25	22	22	22
DD208.50.13	13		28	28	27	27	26	26	25	25
DD208.60.13	13		32	30	30	25	25	22	22	22
DD2010.50.10	10			26	26	25	25	24	24	24
DD2010.60.13	13			32	30	30	25	22	22	22
DD2010.70.16	16			35	35	35	33	33	32	32
DD258.52.13	13			26	26	26	26	24	24	24
DD258.60.13	13			28	28	26	26	25	25	25
DD2510.60.13	13			28	28	26	26	25	25	25
DD2510.70.16	16			35	35	34	34	32	32	32
DD25125.60.13	13			30	30	30	28	28	26	26
DD25125.70.16	16			35	35	34	34	32	32	32
DD25125.80.16	16			36	36	36	35	35	34	34
DD25125.90.16	16			45	45	43	43	42	42	40
DD2516.85.16	16			45	45	43	43	42	42	40
DD3210.70.13	13			34	34	33	33	32	32	30
DD3210.80.13	13			36	36	35	35	34	34	33
DD32125.80.16	16			43	43	42	42	42	40	40
DD32125.90.16	16			45	45	43	43	42	42	40
DD32125.100.16	16			55	50	48	46	45	45	42
DD3216.90.16	16			45	45	43	43	42	42	40
DD3216.100.16	16			55	50	48	46	45	45	42
DD4020.100.16	16			55	50	48	46	45	45	42
DD4020.125.25	25				60	55	50	45	42	42
DD4020.140.25	25				80	75	70	60	55	50

Above dimensions are general. Please contact us for special dimensions and further information.

More
Leg brush holders
(5 of 6)



- Overview
- Leg brush holders
- Brush holders with clamps
- Brush holder bolts
- Self-recolling springs
- Tubular brush holders
- Small slipping systems
- Flange brush holders /Brush rockers

U-bolt brush holders

TYPE DDB

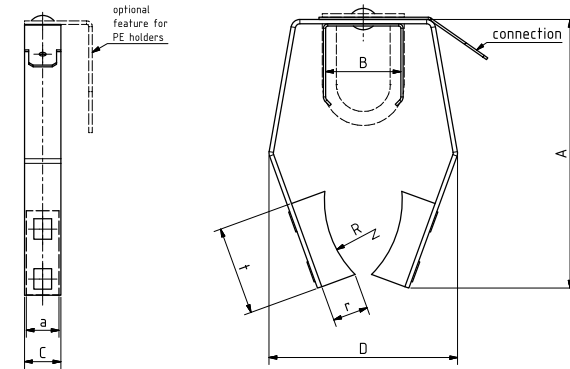

Type number	Brush dimensions			Phase/PE	A	B	C	D	Connection	R	max. current
	t	a	r								
DDB206.51.15.99	20	6	8	phase	51	15	6	41	push-on terminal 4,8	15	16 A
DDB2064.70.18.99	20	6.4	8	phase	70	18	8	59	thread M5	25	25 A
DDB2064.70.18.98	20	6.4	8	PE	70	18	8	59	thread M5	25	25 A
DDB2064.70.18.97	20	6.4	8	phase	70	18	8	59	push-on terminal 6,3	25	16 A
DDB2064.70.18.96	20	6.4	8	PE	70	18	8	59	push-on terminal 6,3	25	16 A
DDB208.625.18.99	20	8	8	phase	62.5	18	8	44	push-on terminal 6,3	22.5	16 A
DDB208.625.18.98	20	8	8	PE	62.5	18	8	44	push-on terminal 6,3	22.5	16 A
DDB208.70.18.99	20	8	8	phase	70	18	8	59	thread M6	25	50 A
DDB208.70.18.98	20	8	8	PE	70	18	8	59	thread M6	25	50 A

U-bolt brush holders are available with copper-graphite as well as silver-graphite brushes.

Spindle for U-bolt brush holders

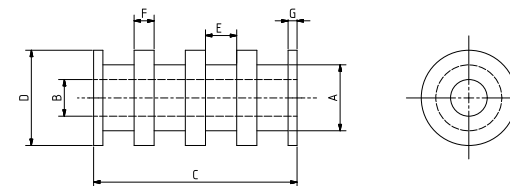

Type number	Suitable for type	A	B	C	D	E	F	G
DDB.Rolle.16.4	DDB206	16	8	47.5	22	6.5	5.5	2.5
DDB.Rolle.18.4	DDB2064, DDB208	18	10	55.5	26	8.5	5.5	2.5

More
Leg brush holders
(6 of 6)



- Overview
- Leg brush holders
- Brush holders with clamps
- Brush holder bolts
- Self-recoiling springs
- Tubular brush holders
- Small slipping systems
- Flange brush holders /Brush rockers

Double brush holders with clamps

TYPE TBS

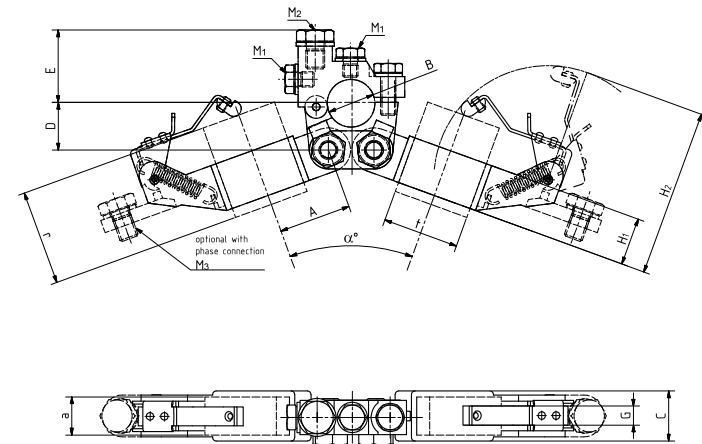

Type number	Brush dimensions			A	B	C	D	E	G	H ₁	H ₂	α°	M ₁	M ₂	M ₃	Phase terminals	Adjustable brush pressure
	t	a	r														
TBS4.168.16.0	16	8	25	16	16	14	17	22.5	6	20	62	40-60	M5	M6	-	0	no
TBS4.168.16.2	16	8	25	16	16	14	17	22.5	6	20	62	40-60	M5	M6	M3	2	no
TBS4.208.16.0	20	8	25	22	16	15	17	22.5	6	16	57	40-60	M5	M6	-	0	no
TBS4.208.16.2	20	8	25	22	16	15	17	22.5	6	16	57	40-60	M5	M6	M6	2	no
TBS4.2010.16.0	20	10	32	22	16	16	17	22.5	6	20	62	40-60	M5	M6	-	0	no
TBS4.2010.16.2	20	10	32	22	16	16	17	22.5	6	20	62	40-60	M5	M6	M6	2	no
TBS3.2510.16.0	25	10	32	25	16	15.5	19.5	25	6	20	74	40-60	M6	M6	-	0	no
TBS4.2510.16.0.V	25	10	32	26	16	17	19.5	22.5	6	20	63	40-60	M5	M6	-	0	yes
TBS4.2510.20.0.V	25	10	32	26	20	17	19.5	24.5	6	20	63	40-60	M5	M6	-	0	yes
TBS3.25125.16.0	25	12.5	32	25	16	17.5	19.5	25	6	20	74	40-60	M6	M6	-	0	no
TBS4.25125.20.0.V	25	12.5	32	26	20	20	19.5	24.5	8	20	63	40-60	M5	M6	-	0	yes
TBS4.32125.16.2	32	12.5	40	32	16	21	27.5	22.5	10	20	70	40-60	M8	M10	M10	2	no
TBS3.3216.25.0.V	32	16	40	34	25	22	26	31	10	25	79	40-60	M8	M10	-	0	yes
TBS4.3216.20.2.V	32	16	40	32	20	24	27.5	32	10	25	76	40-60	M8	M10	M10	2	yes
TBS3.3220.25.0.V	32	20	40	34	25	26	26	31	10	25	79	40-60	M8	M10	-	0	yes
TBS4.3220.20.2	32	20	40	32	20	26	27.5	32	10	25	86	40-60	M8	M8	M10	2	no
TBS3.3225.25.0	32	25	50	32	25	31	24.5	29	10	30	80	40-60	M8	M10	-	0	no
TBS2.4020.25.0	40	20	40	38	25	25.5	28	46.5	12	26.5	78	40-60	M8	M10	-	0	no
TBS3.4020.25.0.V	40	20	40	38	25	26	26	31	10	25	79	40-60	M8	M10	-	0	yes
TBS3.4020.25.2	40	20	40	38	25	26	25	31	10	25	79	40-60	M8	M10	M10	2	no
TBS4.4032.25.0.V	40	32	50	36	25	37	30	34.5	10	28	86	40-60	M8	M10	-	0	yes
TBS4.4032.25.2.V	40	32	50	36	25	37	30	34.5	10	28	86	40-60	M8	M10	M10	2	yes

Above dimensions are general. Please contact us for special dimensions and further information.

More Brush holders with clamps (1 of 2)



Overview
Leg brush holders
Brush holders with clamps
Brush holder bolts
Self-recoiling springs
Tubular brush holders
Small slipping systems
Flange brush holders /Brush rockers

Single brush holders with clamps

TYPE GH

with clamp version K

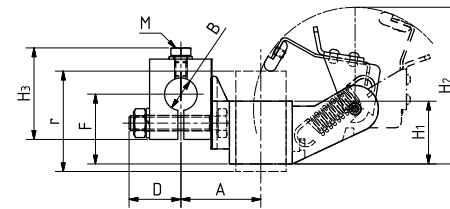

with clamp version L

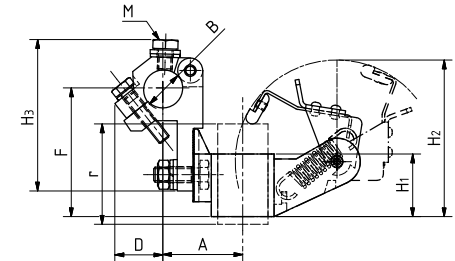

For both clamp versions

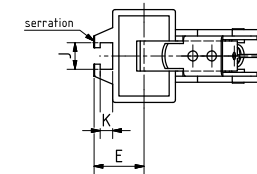
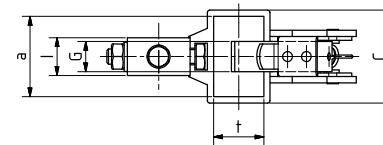

Type number	Brush dimensio			Brush holders							with clamps								
	t	a	r	C	E	G	H ₁	H ₂	J	K	De-sign	A	B	C	D	F	H ₃	I	M
GH510	5	10	20	14.5	12.5	6	15	36.5	9.5	4.5									
GH6310	6.3	10	20	14.5	13.2	6	15	37	9.5	4.5									
GH810	8	10	20	14.5	14	6	15	38.5	9.5	4.5									
GH63125	6.3	12.5	25	17	13.2	6	20	47.5	9.5	4.5									
GH8125	8	12.5	25	17	14	6	20	47	9.5	4.5									
GH10125	10	12.5	25	17	15	6	20	47	9.5	4.5									
GH816	8	16	32	20.5	14	8	22	56	10.5	5									
GH1016	10	16	32	20.5	15	8	22	56	10.5	5									
GH12516	12.5	16	32	20.5	16.3	8	22	55	10.5	5									
GH6320	6.3	20	32	24.5	13.2	8	25	56	10.5	5									
GH820	8	20	32	24.5	14	8	25	56	10.5	5									
GH1020	10	20	32	24.5	15	8	25	57	10.5	5									
GH12520	12.5	20	32	24.5	16.3	8	25	60	10.5	5									
GH1620	16	20	32	24.5	18	8	25	60	10.5	5									
GH825	8	25	32	29.5	14	10	25	63	10.5	5									
GH1025	10	25	40	29.5	15	10	25	63	10.5	5									
GH12525	12.5	25	40	29.5	16.3	10	25	67	10.5	5									
GH1625	16	25	40	29.5	18	10	25	69	10.5	5									
GH2025	20	25	40	29.5	20	10	25	70	10.5	5									
GH12532	12.5	32	40	37.5	16.3	12	25	60	10.5	5									
GH1632	16	32	40	37.5	18	12	25	61	10.5	5									
GH2032	20	32	40	37.5	20	12	25	64	10.5	5									
GH2532	25	32	45	37	22.5	10	30	70	10.5	5.2									

Please specify required clamp version and dimensions.

Above dimensions are general. Please contact us for special dimensions and further information.

More Brush holders with clamps (2 of 2)

Overview

Leg brush holders

Brush holders with clamps

Brush holder bolts

Self-recoiling springs

Tubular brush holders

Small slipping systems

Flange brush holders /Brush rockers

Brush holder bolts

TYPE B

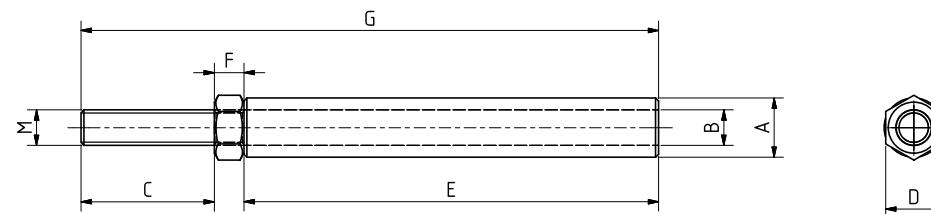

Type number	M	A	B	C	D	E	F	G
B30	M8 x 1.25	10	8	9	13	32	4	45
B31	M8 x 1.25	10	8	13	13	45	4	62
B32	M8 x 1.25	10	8	13	13	70	4	87
B33	M8 x 1.25	10	8	39	13	90	6	135
B34	M8 x 1.25	12	8	39	13	100	6	145
B35	M8 x 1.25	13	8	44	13	100	6	150
B35a	M10 x 1.5	13	10	42	17	100	8	150
B36	M10 x 1.5	14	10	37	17	100	8	145
B37	M10 x 1.5	15	10	37	17	110	8	155
B38	M10 x 1.5	16	10	47	17	110	8	165
B39	M12 x 1.75	18	12	45	19	120	10	175
B40	M12 x 1.75	20	12	45	19	140	10	195
B41	M12 x 1.75	22	12	50	19	140	10	200
B42	M12 x 1.75	23	12	55	19	140	10	205
B43	M12 x 1.75	25	12	55	19	140	10	205

Insulation available in different materials, such as plastic, laminated paper or fibre glass.
Above dimensions are general. Please contact us for special dimensions and further information.

- Overview
- Leg brush holders
- Brush holders with clamps
- Brush holder bolts
- Self-recoiling springs
- Tubular brush holders
- Small slipping systems
- Flange brush holders /Brush rockers

Self-recoiling springs

TYPE RFT

Self-recoiling springs - Designs

Design 1

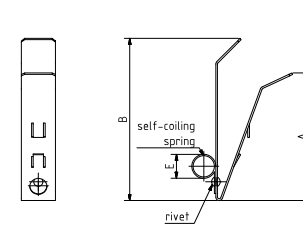

Design 2

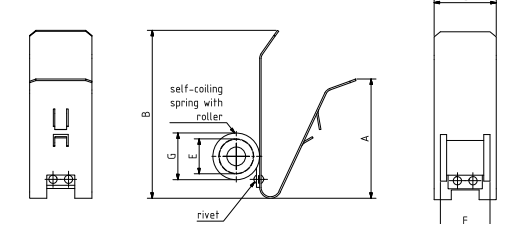

Design 3

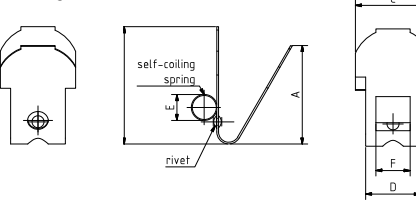

Design 4

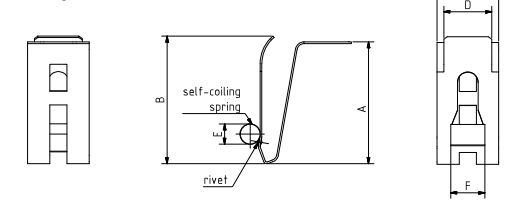

Design 5

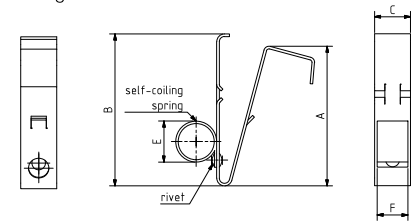

Design 6

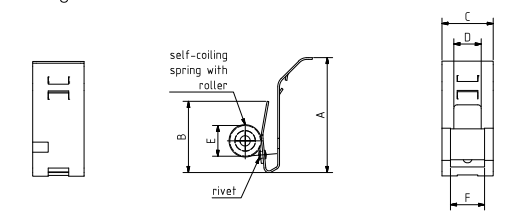

Design 7

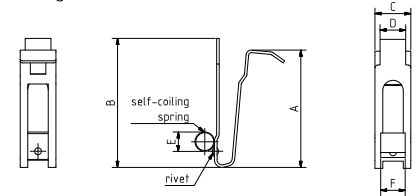

Design 8

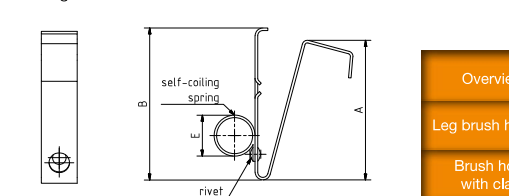

All types are available in several sizes and with different brush pressures.

For further information as well as our enquiry and order forms, please refer to www.mack-kohlebuersten.de. Above dimensions are general. Please contact us for special dimensions and further information.



- Overview
- Leg brush holders
- Brush holders with clamps
- Brush holder bolts
- Self-recoiling springs
- Tubular brush holders
- Small slipping systems
- Flange brush holders /Brush rockers

Tubular brush holders

TYPE KH

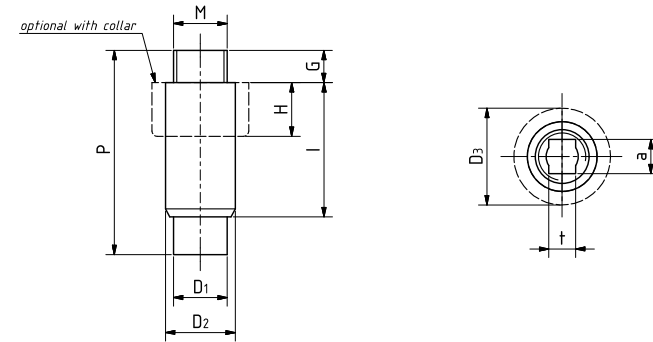

Type number	t	a	D ₁	D ₂	P	I	M	G	with collar	
									H	D ₃
KH34	3	4	7						at customer's option	
KH364	3	6,4	9						at customer's option	
KH44	4	4	8						at customer's option	
KH45	4	5	8						at customer's option	
KH48	4	8	12						at customer's option	
KH48159	4,8	15,9	21						at customer's option	
KH55	5	5	9						at customer's option	
KH56	5	6	9						at customer's option	
KH564	5	6,4	10						at customer's option	
KH58	5	8	12						at customer's option	
KH510	5	10	14						at customer's option	
KH5135,49	5	13,5	made of brass sheet	-	49	-	-	-	-	-
KH515,44	5	15	made of brass sheet	-	44	-	-	-	-	-
KH66	6	6	10						at customer's option	
KH69	6	9	13						at customer's option	
KH613,335	6	13	made of brass sheet	17,1	33,5	25	M19 x 1	8,5	12,5	20,1
KH613,425	6	13	made of brass sheet	17,1	42,5	34	M19 x 1	8,5	21,5	20,1
KH616	6	16	21						at customer's option	
KH6311,42	6,3	11	made of brass sheet	-	42	-	-	-	-	-
KH6311,22	6,3	11	made of brass sheet	-	22	-	-	-	-	-
KH648	6,4	8	12						at customer's option	
KH6410	6,4	10	14						at customer's option	
KH64125	6,4	12,5	16						at customer's option	
KH64125,45	6,4	12,5	made of brass sheet	-	45	-	-	-	-	-
KH88	8	8	13						at customer's option	
KH810	8	10	16						at customer's option	
KH810,28	8	10	made of brass sheet	-	28	-	-	-	-	-
KH812	8	12	16						at customer's option	
KH8125,25	8	12,5	made of brass sheet	-	25	-	-	-	-	-
KH10125	10	12,5	18						at customer's option	

Insulation available in different materials, such as plastic, laminated paper or fibre glass.

More
Tubular brush
holders
(1 of 3)



- Overview
- Leg brush holders
- Brush holders with clamps
- Brush holder bolts
- Self-recoiling springs
- Tubular brush holders
- Small slipping systems
- Flange brush holders /Brush rockers

Connections

Thread



Groove



Blade terminal



Designs

Collar

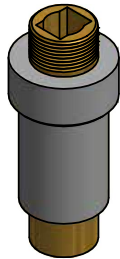

Knurl



Inside thread



Screw caps with inside thread

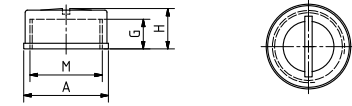

Type number	Thread M	Thread depth G	External diameter A	Overall height H
A 7 x 0.75/5	M7 x 0.75	5	10.5	7.5
A 7 x 0.75/6	M7 x 0.75	6	10.5	7.5
A 8 x 0.75/6	M8 x 0.75	6	12.5	8.5
A 8 x 1/6	M8 x 1	6	12.5	8
A 9 x 0.75/6	M9 x 0.75	6	12.5	8
A 9 x 1/6	M9 x 1	6	12.5	8.5
A 10 x 0.75/4	M10 x 0.75	4	13.5	5.5
A 10 x 1/5	M10 x 1	5	13	8
A 10 x 1/6	M10 x 1	6	13	9
A 10 x 1/7	M10 x 1	7	13	10
A 12 x 1/6	M12 x 1	6	18	10
A 12 x 1/6.5	M12 x 1	6.5	17	10
A 12 x 1/7	M12 x 1	7	17	10
A 12 x 1/7C	M12 x 1	7	15	10
A 13 x 1/6	M13 x 1	6	17	10
A 13 x 1/7	M13 x 1	7	17	10
A 14 x 1/7	M14 x 1	7	19	12
A 14 x 1/7C	M14 x 1	7	17.5	10
A 15 x 1/6.5	M15 x 1	6.5	20	10
A 16 x 1/7	M16 x 1	7	22	11
A 16 x 1/7C	M16 x 1	7	20	9.5
A 17 x 1/7	M17 x 1	7	22	11
A 18 x 1/7	M18 x 1	7	22.5	11.5
A 19 x 1/9.5	M19 x 1	9.5	23	13
A 20 x 1/8	M20 x 1	8	25	13

Screw caps with external thread

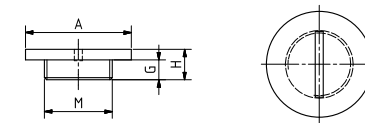

Type number	Thread M	Thread depth G	External diameter A	Overall height H
AG 8 x 0.75/4	M8 x 0.75	4	11	5.5
AG 12 x 1/5	M12 x 1	5	15	7.5
AG 16 x 1/6	M16 x 1	6	end-to-end thread	
AG 16 x 1/5	M16 x 1	5	25	7.5
AG 20 x 1/6	M20 x 1	6	end-to-end thread	
AG 7/8"	7/8" (22.2 mm)	5	end-to-end thread	
AG 23 x 1/6	M23 x 1	6	29	9
AG 23 x 1/6C	M23 x 1	6	26	9
AG 24 x 1/6	M24 x 1	6	30	9
AG 24 x 1.5/9	M24 x 1.5	9	end-to-end thread	

More Tubular brush holders (2 of 3)



- Overview
- Leg brush holders
- Brush holders with clamps
- Brush holder bolts
- Self-recoiling springs
- Tubular brush holders
- Small slipping systems
- Flange brush holders /Brush rockers

Spark plug holder & telescope conductor

TYPE ST



Design 1
telescope conductor
with telescope gauze brush

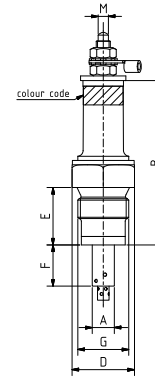

Design 2
telescope conductor (with brass sleeve)
with telescope gauze brush

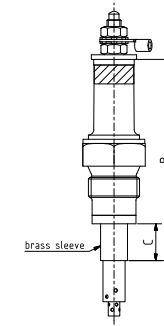

Design 3
spark plug holder

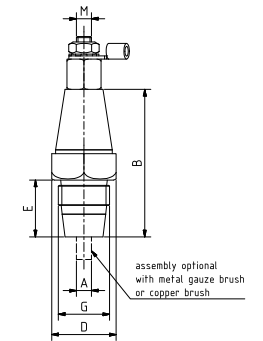

Type number	A	B	C	D	E	F	G	M	Colour ring	Assembly with	Design
ST4.45.1415.SW17.99*	4	45	-	SW17	15	-	M14 x 1.5	M4	-	-	3
ST5.41.1415.SW17.00	5	41	-	SW17	12	13	M14 x 1.5	M5	-	gauze brush	1
ST5.41.1415.SW17.01	5	41	-	SW17	12	13	M14 x 1.5	M5	-	copper brush	1
ST5.41.1415.SW17.99*	5	41	-	SW17	12	-	M14 x 1.5	M5	-	-	1
ST6.52.1815.SW22.00	6	52	-	SW22	19	20	M18 x 1.5	M5	-	gauze brush	1
ST6.52.1815.SW22.01	6	52	-	SW22	19	20	M18 x 1.5	M5	-	copper brush	1
ST6.52.1815.SW22.99*	6	53	-	SW22	19	-	M18 x 1.5	M5	-	-	1
ST6.53.1615.SW19.00	6	53	-	SW19	20	19	M16 x 1.5	M5	-	gauze brush	1
ST6.53.1615.SW19.01	6	53	-	SW19	20	19	M16 x 1.5	M5	-	copper brush	1
ST6.53.1615.SW19.99*	6	53	-	SW19	20	-	M16 x 1.5	M5	-	-	1
ST6.53.1815.SW22.00	6	53	-	SW22	17	22	M18 x 1.5	M5	-	gauze brush	1
ST6.53.1815.SW22.01	6	53	-	SW22	17	22	M18 x 1.5	M5	-	copper brush	1
ST6.53.1815.SW22.99*	6	53	-	SW22	17	-	M18 x 1.5	M5	-	-	1
ST6.55.1815.SW22.99*	6	55	-	SW22	19	-	M18 x 1.5	M5	-	-	3
ST6.87.1615.SW19.00	8	87	13	SW19	20	13	M16 x 1.5	M5	yellow	gauze brush	2
ST8.58.1815.SW22.00	8	58	-	SW22	20	14	M18 x 1.5	M5	red	gauze brush	1
ST8.58.1815.SW22.01	8	58	-	SW22	20	14	M18 x 1.5	M5	red	copper brush	1
ST8.71.1815.SW22.00	8	71	13	SW22	20	13	M18 x 1.5	M5	-	gauze brush	2

Above dimensions are general. Please contact us for special dimensions and further information.
* Type numbers ending with .99* are without assembly as metal gauze brushes or copper brushes.

More
Tubular brush
holders
(3 of 3)

- Overview
- Leg brush holders
- Brush holders with clamps
- Brush holder bolts
- Self-recoiling springs
- Tubular brush holders
- Small slipping systems
- Flange brush holders /Brush rockers

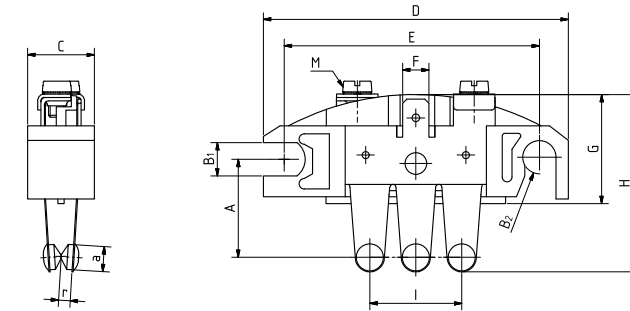

Type number	Brush type	a	r	A	B ₁	B ₂	C	D	E	F	G	H	I	M	max. current*
FSAGR.01.00.99.00	Copper-graphite brushes	6	3	23	8	8	16	73	60	push-on terminal 6.3	26	41.5	22	M4	25 A
FSAGR.01.01.99.00	Silver-graphite brushes	6	3	23	8	8	16	73	60	push-on terminal 6.3	26	41.5	22	M4	25 A
FSAKL.01.00.99.00	Copper-graphite brushes	3	1.5	12.5	5	5	12	50	40	solder lug 6 mm	12	27	14	-	15 A
FSAKL.01.01.99.00	Silver-graphite brushes	3	1.5	12.5	5	5	12	50	40	solder lug 6 mm	12	27	14	-	15 A

Plane grinding rings and further equipment for current transmission systems are also available from MACK. For further information, please refer to our brochure „Current Transmission Systems“.

Our small slipring systems are designed for plane grinding rings with diameters of 50 mm and 101.5 mm. Other dimensions are available on request. * Figures based on a duty rating of 60%.

- Overview
- Leg brush holders
- Brush holders with clamps
- Brush holder bolts
- Self-recolling springs
- Tubular brush holders
- Small slipring systems
- Flange brush holders /Brush rockers

Flange brush holders

TYPE FH



Version A

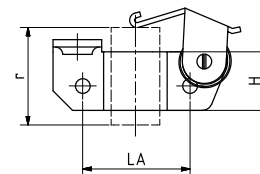

Version B

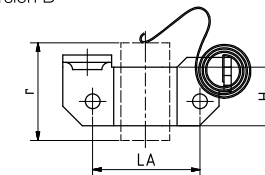

connection

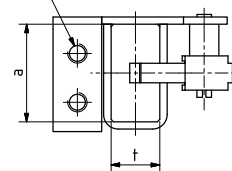

connection

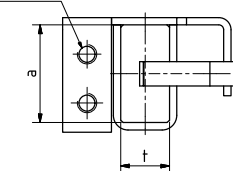

Type number	Brush dimension t	a	r	H	LA	Connection	Version
FH48.85.A.99.00	4	8	10	8.5	16	-	A
FH56.8.B.99.00	5	6	14	8	12	M3	B
FH5125.10.A.99.00	5	12.5	17	10	16	M3	A
FH648.10.A.99.00	6.4	8	20	10	16	M3	A
FH648.10.B.99.00	6.4	8	19	10	14	M3	B
FH6410.10.B.98.00	6.4	10	19	10	15	M3 + push-on terminal 4.8	B
FH6410.10.B.99.00	6.4	10	19	10	14	M3	B
FH6410.13.B.99.00	6.4	10	23	13	20	push-on terminal 4.8	B
FH64125.10.A.98.00	6.4	12.5	17	10	14	M3	A
FH64125.10.A.99.00	6.4	12.5	16	10	15	2x M3	A
FH64125.18.B.99.00	6.4	12.5	22	18	20	M4	B
FH6416.12.B.99.00	6.4	16	24	12	20	M4	B
FH6416.18.B.99.00	6.4	16	22	18	20	M4	B
FH6416.225.B.99.00	6.4	16	24	22.5	26	2x push-on terminal 6.3	B
FH810.10.A.99.00	8	10	17	10	16	M3	A
FH810.10.B.99.00	8	10	17	10	16	M3	B
FH810.14.B.99.00	8	10	20	14	20	2x M4	B
FH8125.15.A.99.00	8	12.5	24	15	20	2x M3	A
FH8125.225.B.99.00	8	12.5	24	22.5	26	2x push-on terminal 6.3	B
FH816.12.B.99.00	8	16	24	12	20	M4	B
FH1013.19.B.99.00	10	13	26	19	20	-	B
FH1016.12.B.99.00	10	16	21	12	20	M4	B
FH1020.12.B.99.00	10	20	26	12	20	2x M5	B

Further dimensions available on request.

Brush rockers



- Overview
- Leg brush holders
- Brush holders with clamps
- Brush holder bolts
- Self-recolling springs
- Tubular brush holders
- Small slipping systems
- Flange brush holders /Brush rockers



Version A

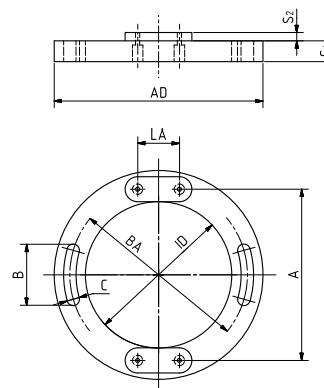

Version B

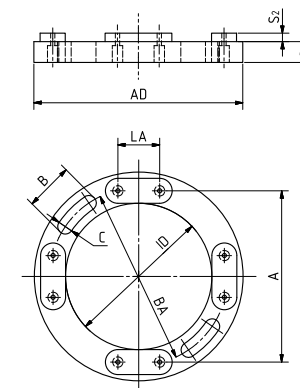

Type number	Version	AD	ID	A	LA	S ₁	S ₂	BA	B	C
BB645,40,A	A	64,5	40	52,5	20	6	4	52	22	4
BB65,40,B	B	65	40	53	20	6	-	52	3	3
BB54,305,A	A	54	30,5	44	20	10	1	(without)		
BB355,20,A	A	35,5	20	25	12	3,2	-	29	2,5	2,5
BB52,23,A	A	52	23	29,3	11	8	-	37	7	7
BB52,23,A	A	52	23	33,5	16	8	-	(without)		
BB53,33,A	A	53	33	40,5	14	8	-	43	4,2	4,2
BB65,35,B	B	65	35	47	20	6	-	52,5	3,2	3,2
BB86,48,B	B	86	48	62,5	20	3	2,3	68	6,3	6,3
BB86,61,B	B	86	61	69	14	10	3,5	75	M4	M4
BB88,56,A	A	88	56	63,2	16	8	3,5	72,5	24	5,5
BB98,55,B	B	98	55	63,5	22	7	0,7	82	15	6

Further dimensions available on request.

Flange brush holders



- Overview
- Leg brush holders
- Brush holders with clamps
- Brush holder bolts
- Self-recolling springs
- Tubular brush holders
- Small slipping systems
- Flange brush holders /Brush rockers