

1 Scope of application

Carbon fiber shaft grounding systems are suited for permanent discharging of shaft currents within the following operational conditions:

- Lowest to highest frequency AC-applications
- High demands regarding cleanness around application area
- Minor contamination of the shaft (e.g. oil film)
- High peripheral speeds
- Crowded installation area
- For tangential shaft contacting

2 Installation

The maximum deflection of the graphite fiber rod shall not exceed 3.5 mm per 100 mm length. With correct installation the fiber strand's deflected position should deviate from its initial position by approx. 1-3mm.

For an ideal grounding performance the shaft surface has to be roughness depth of $R_a < 1,6$ / $R_z < 7 \mu\text{m}$ and free of dust or oil. The shaft shoulder where the fiber strand will run on has to be at least 10mm wide. Use in shaft areas where bores, slopes, feather key grooves and radii can affect the system's functionality is not feasible.

The connection cables have to be connected to a suitable grounding point close to its installation position. The customer is free to shorten the cable if applicable. Professional installation requires to tailor the cable ends with non-magnetically cable lugs or terminals. A good contact to the grounding point is to be observed.

D min.	D max.	Notch	α
29	35	2	0
45	65	3	18
65	110	4	36
110	150	5	54
150	200	6	72
200	250	7	90
300	400	8	108
450	500	9	126

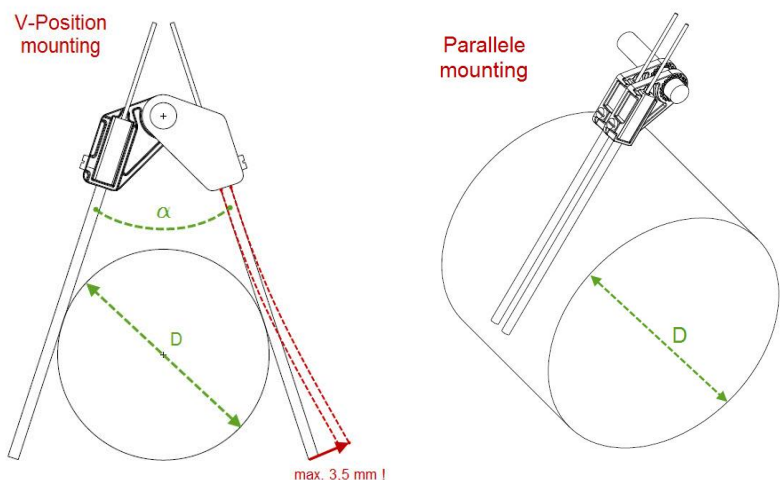

3 Accessories

C-Fiber shaft grounding systems are available in various types and configurations and can be equipped with optional accessories to adapt to customer's demands.

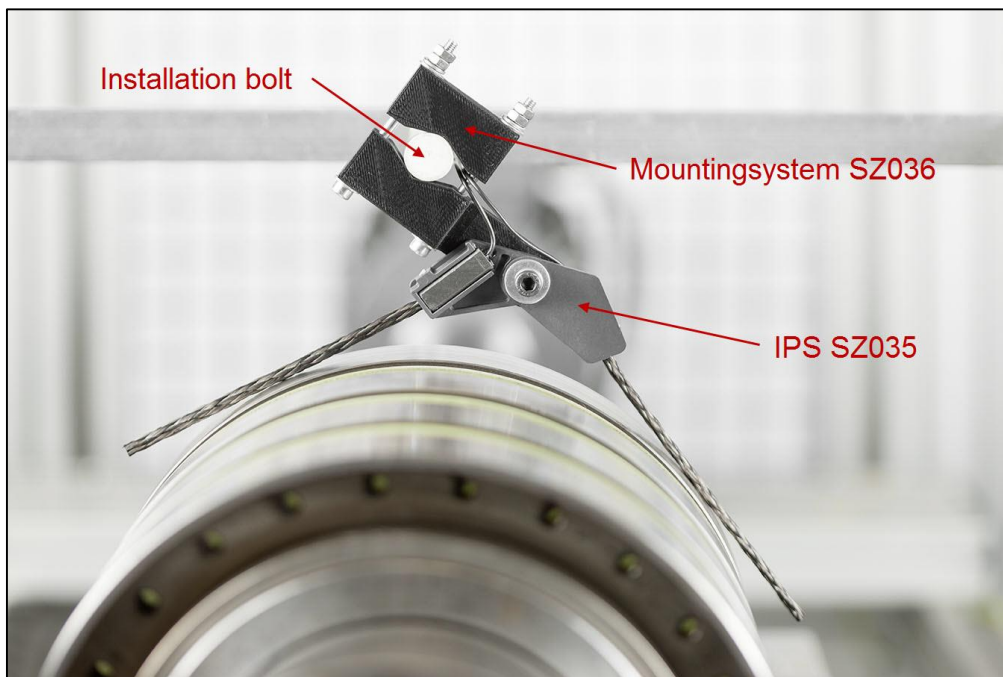
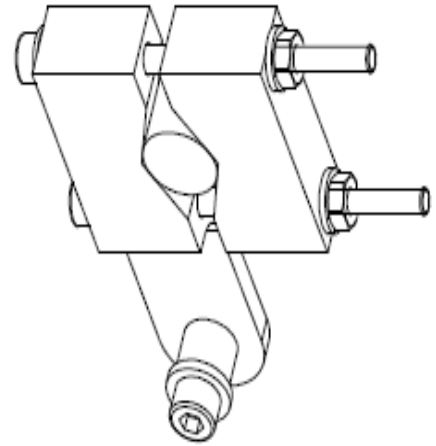

Picture 1: IPS-Mountingsystem

Schunk Wien Ges.m.b.H.

Subject to alternations

We reserve all rights in this document and in the information contained therein. Reproduction, use or disclosure to third parties without written permission is strictly forbidden.

© Schunk Wien Ges.m.b.H., all rights reserved